

# Carseland Cogeneration Plant



## Facility Highlights

### Configuration:

2 x 0 cogeneration.

### Location:

Agrium Nitrogen Operations Plant,  
Carseland, Alberta.

### In-Service Date:

December 2001.

### Capacity:

80 MW electrical and 120 tonnes/hr of steam.

### Fuel:

Natural Gas.

### Environmental Features:

High fuel efficient – 75% at design conditions  
Dry low NOx combustion technology to minimize  
air emissions.

### Owner:

TransCanada Energy Ltd. (through contract  
with Agrium).

Carseland is an 80 megawatt (MW) industrial cogeneration plant located entirely within the fenced boundary of Agrium's Carseland Nitrogen Operations.

The plant was designed as a dual train configuration in order to provide steam system redundancy and the high level of reliability required by the host site.

TransCanada Energy Ltd. participates in Alberta's competitive market for electricity.

# Carseland Cogeneration Plant

The cogeneration plant is configured around two 40 MW General Electric LM6000 PD combustion turbines, each with an associated duct burner and heat recovery steam generator (HRSG). The combustion turbines and duct burners are equipped with low emissions combustion technology to minimize environmental impact.

Natural gas is burned in the combustion turbines to generate electricity and hot exhaust gases. The exhaust gases from each turbine are then augmented by duct firing and passed through an HRSG to generate high-pressure superheated steam for use in Agrium's nitrogen operations process. Reliance on duct burning under normal operating conditions allows the cogeneration plant to quickly respond to changes in steam demand from the host site. Also, the presence of duct burners allows a single combustion turbine-HRSG train to meet the entire host site steam demand.

The host site consumes all of the steam generated by the cogeneration plant, and the host site provides all of the high pressure feed water required by the cogeneration plant.

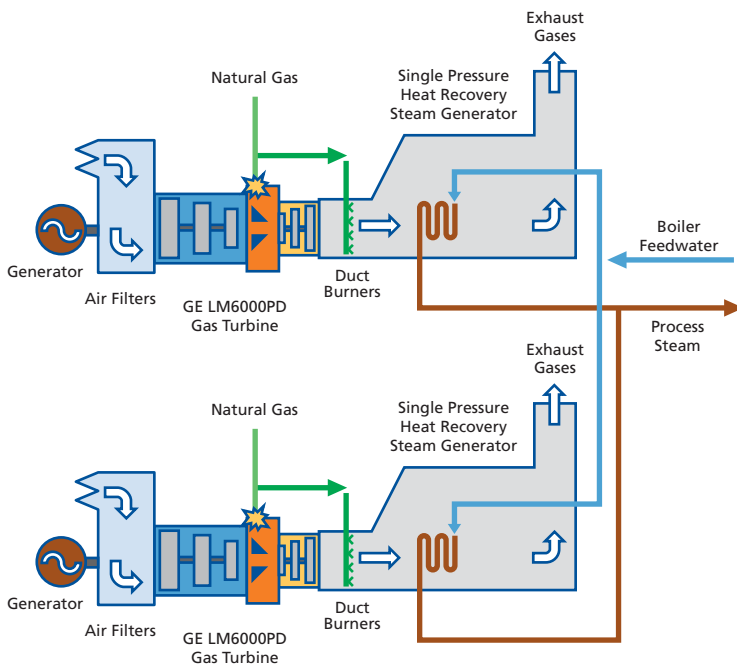
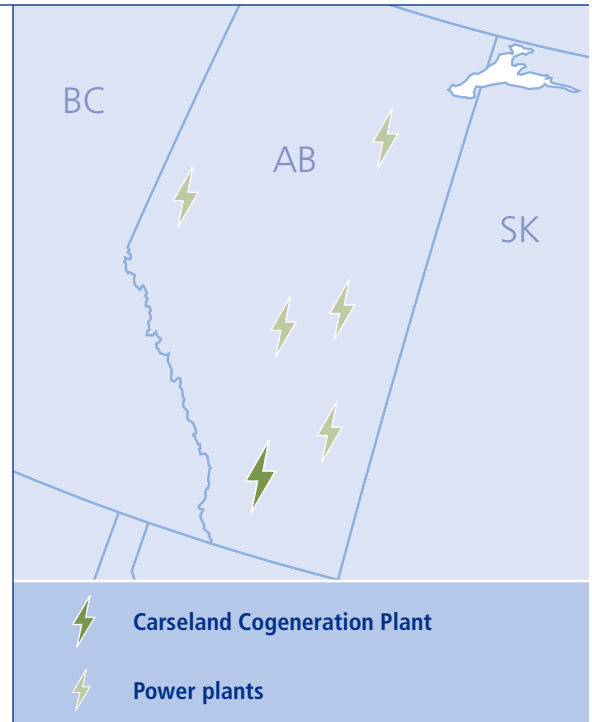

**Carseland Plant Schematic**

## For further information on this facility, contact:

Pat Drysdale, Site Manager  
Telephone: 403.936.3334  
E-mail: pat\_drysdale@transcanada.com

## TransCanada

450 First Street S.W.  
Calgary, Alberta  
T2P 5H1  
1.800.661.3805  
www.transcanada.com